

Design and Development of a Smart Pet Feeder: Enhancing Pet Care Through Automation

Mr. Jajati Mallick
CSE Department
MITS
Rayagada, Odisha.
mallick.jajati@gmail.com

Ms. Suchismita Mahapatra
CSE Department
MITS
Rayagada, Odisha.
suchi.nita@gmail.com

Maheswar Majhi
CSE Department
MITS
Rayagada, Odisha.
maheswarmajhi502@gmail.com

Abstract-In Today's busy lifestyle, pet owners face many problems in ensuring regular and balanced feeding for their beloved pets ensuring pets receive the right amount of food at the right time. This Smart pet feeder addresses this issue by employing a based device to offer a fully automated smart feeder. The convenience of the owner and the well-being of the pets are both enhanced by this innovative system incorporates various technologies and devices. When feeding time arrives, a speaker with pre-recorded voice messages gently calls the pet to the food area, ensuring they are aware it's time to eat, in case the pet does not eat food immediately or pet leaves after eating a small portion of food then the system will call pet with a periodic reminder, encouraging them to eat food at their own pace. The device closes the pet's food bowl automatically after the pet leaves the pet feeder to guard against contamination and food spoiling and maintain the quality of the food. It includes real-time food level monitoring, and calling the pet at a scheduled time. It ensures that pets receive timely and sufficient meals, reduces food waste, and safeguards food quality.

Keywords: *Microcontroller, Load Sensor, Low-cost Moisture, ESP-32, Embedded System*

I. INTRODUCTION

Pet ownership is a cherished aspect of many households worldwide, with millions of families welcoming pets into their lives as valued companions. As the bond between humans and their furry friends grows stronger, so does the desire to provide them with the best possible care and attention. Central to this care is the crucial task of feeding, ensuring that pets receive proper nutrition and timely meals. In recent years, technological advancements have permeated various aspects of daily life, including pet care [1]. One such innovation that has gained significant attention is the Smart Pet Feeder – a device designed to automate feeding schedules, monitor pets' eating habits, and provide convenience to pet owners. This paper delves into the design and development of such a device, exploring its functionalities, benefits, and potential impact on pet care practices. The design and development of a Smart Pet Feeder encompass a range of considerations, from ensuring pet safety and portion control to providing flexibility in feeding

schedules. This paper examines the hardware components, software development, and user interface design required to create a reliable and effective solution.

Furthermore, the functionality of the Smart Pet Feeder goes beyond mere automation. It enables pet owners to remotely monitor their pets' feeding activities, adjust feeding schedules as needed, and receive real-time notifications about their pets' well-being. By leveraging connectivity features and intelligent algorithms, the Smart Pet Feeder offers peace of mind to pet owners, even when they are away from home. This paper also discusses the benefits of adopting such technology in pet care routines, including the convenience it offers to busy pet owners, the promotion of pets' health and well-being through controlled feeding, and the assurance of consistent care even in the owner's absence. Despite its potential advantages, the development of a Smart Pet Feeder is not without challenges. Issues such as hardware reliability, connectivity disruptions, and the diversity of pets' dietary needs must be addressed to ensure the device's effectiveness and acceptance among pet owners. Looking ahead, the Smart Pet Feeder represents just the beginning of advancements in pet care technology. With further integration of artificial intelligence and machine learning, as well as improvements in design and sustainability, the future holds even greater possibilities for enhancing the lives of both pets and their owners.

This Proposed system is to help the people who have pets and people who are afraid to buy pets due to their busy lives they cannot take care of them every day. We all know that people are too busy in day-to-day life with office work and other stuff, many people out there want to buy companions but cannot feed them because they are busy. So proposed a system that is fully automated to feed pets in the absence of an owner [2]. A built-in speaker plays a pre-recorded voice gently calling out to the pet, this unique interaction not only captures the pet's attention but also establishes a routine that fosters a sense of security and excitement, the pet was waiting eagerly for feeding. Some pets can be picky eaters at times, so this smart pet feeder takes proactive measures to ensure their well-being. If the pet does not eat food immediately or pet leaves after eating a small portion of food, then the system will gently call the pet to encourage the pet to return to the food and consume their meal at their own pace. The integration of body sensor

device technology in smart pet feeder system. when pet approaches near the pet feeder, the sensor detects pets' presence which sent signal to open the bowl. This idea helps a lot to save food from spoilage dust particles and react with oxygen. This smart pet feeder takes care of a crucial issue that goes beyond feeding by maintaining food quality. We keep dust and other impurities from contaminating the food leftover by pet by automating the feeding bowl's closing mechanism when the pet has done eating. By doing this, owner can reduce waste while maintaining the food nutritious value. The smart pet feeder system is to the well-being of pets. Through an idea of calling pet at its mealtime and opening the bowl when pets arrive to smart pet feeder system and closing it when pets left the food bowl to preserve the food from spoilage. Our smart pet feeder's main purpose is to relieve pet owners of their stress while they remain busy with work. For pet feeding, it is an improved system to save food from spoiling by dust and ensure pets receive the right amount of food at the right time, minimize food waste, and protect food quality. Refiling of the bowl is scheduled by the owner, and it is fully automated, but refiling of food storage is done by the owner before it gets empty.

In summary, this paper aims to provide a comprehensive understanding of the design and development of the Smart Pet Feeder, exploring its functionalities, benefits, challenges, and future directions. By shedding light on this innovative pet care solution, we hope to contribute to the ongoing conversation about improving the well-being of our beloved animal companions.

II. LITERATURE REVIEW

The advancement of smart pet feeders has been a subject of significant interest in recent years, with researchers exploring various aspects of their design, functionality, and applications. Suffian et al. (2021) contributed to this field by presenting a detailed study on a reliable smart pet feeding machine developed using an Arduino Uno starter kit[1]. The study likely delves into the hardware components, such as the feeding mechanism and sensors, as well as the programming and functionality of the feeder. It may discuss the considerations for ensuring reliability and safety in the design, providing valuable insights into the implementation of microcontroller-based systems for smart pet feeding. Marlina (2023) focused on the design of a smart pet feeder using Passive Infrared (PIR) sensors[2]. This approach is particularly interesting as it explores how sensors can detect pet presence and trigger feeding accordingly. The paper may discuss the integration of PIR sensors into the feeder, the detection algorithms used, and the overall energy efficiency of the system. By leveraging sensor technology, Marlina's work likely provides insights into creating pet-friendly and responsive feeding solutions that adapt to the pets' needs and behaviors. Jukan et al. (2017) provided a systematic review on smart computing and sensing technologies for animal welfare, which includes a discussion on smart pet feeders[3]. This review likely covers various sensor technologies, data processing techniques, and their

applications in monitoring and improving animal well-being. It may highlight the importance of integrating advanced sensing technologies into pet feeders to enable real-time monitoring of pets' feeding behaviors and health indicators.

Boateng and Akparibo (2022) introduced a multifunctional automatic dog-feeder with Bluetooth and Wi-Fi connectivity, emphasizing the importance of connectivity features in enhancing user interaction and remote monitoring[4]. Their work may discuss the implementation of these features, the user interface design, and the implications for pet owners in terms of convenience and peace of mind. Additionally, the paper may touch upon the challenges and considerations in ensuring reliable connectivity and data security in smart pet feeders. Bembde et al. (2023) explored the concept of robotic day-care for pets using sensors and Raspberry Pi[5]. Although not specifically focused on pet feeding, their study likely provides insights into the use of sensors and automation in pet care. It may discuss how sensor data is processed and used to provide interactive experiences and care for pets in the absence of their owners, potentially inspiring future developments in smart pet feeding technology.

In this project proposed by all the authors, one of them incorporated a speaker to alleviate his pet's loneliness. However, they did not use the speaker to call or command their pet to eat when it was time for feeding. Instead, if the pet did not eat during the designated feeding time, the speaker was used to call (command) the pet after some time, encouraging them to eat.

Many of the authors have not proposed any interactive structure for facilitating interaction between the owner and the pet. This absence of interaction can sometimes result in the pet not eating its food, especially when the owner is not present to serve them. To address this issue, we have implemented a structured system that records the owner's voice as a command and issues these commands to the pet at the scheduled mealtime.

III. COMPONENTS USED IN PROPOSED SYSTEM

The suggested smart pet feeder consist of hardware component overview is provided in this section. To provide the user with insights, the ESP-32 Microcontroller is connected with speaker, Load sensor and HX711, LCD and I2C, Bread board, Bowl, Motion sensor which is Ultra Sonic having main functionality in system, and both are controlled by microcontroller.

ESP-32: The ESP32 is a powerful microcontroller developed by Espressif Systems. It has gained popularity for its versatility, low cost, and extensive connectivity options, making it suitable for a wide range of IoT (Internet of Things) applications, including smart pet feeders. One of the key features of the ESP32 is its dual-core processor, which allows for multitasking and efficient handling of various tasks simultaneously. This makes it well-suited for applications where real-time processing and responsiveness are required, such as monitoring sensors and controlling actuators in a smart pet feeder. Additionally, the ESP32 offers built-in Wi-Fi and

Bluetooth connectivity, allowing devices to communicate with each other and with the internet. This enables remote monitoring and control of the pet feeder, as well as integration with other smart home devices and services. The ESP32 also supports a wide range of peripheral interfaces, including GPIO pins, SPI, I2C, UART, and ADC, which can be used to interface with sensors, displays, motors, and other components commonly found in smart pet feeders. This flexibility allows developers to easily customize and expand the functionality of their pet feeder according to specific requirements. Furthermore, the ESP32 is supported by a rich ecosystem of development tools and libraries, making it accessible to both hobbyists and professional developers. Arduino IDE, PlatformIO, and Espressif's own ESP-IDF are among the popular development environments for programming the ESP32. In the context of smart pet feeders, the ESP32 can be used to create a robust and feature-rich solution that offers automated feeding schedules, remote monitoring, and control, as well as integration with other smart home devices. Its low cost, versatility, and ease of use make it an attractive choice for developers looking to create innovative pet care solutions.

Load Sensor: The Load Sensor in smart pet feeder is a 1 kg load sensor and will take weight of bowl as input and send output to microcontroller unit and microcontroller check whether the food in bowl is completely eaten or not, after receiving the input ESP32 will conclude the further process. HX711 is used a part of load sensor it will amplify these small signals up to 128 times and it incorporates a high-resolution 24-bit ADC that can convert the analog signal into a digital representation with high precision. Load sensors work on the principle of strain gauge technology, where a strain gauge is bonded to a flexible material (usually metal) that deforms under load. As the material deforms, the strain gauge undergoes a change in resistance, which is directly proportional to the applied force. This change in resistance is then converted into an electrical signal that can be measured and interpreted by a microcontroller or other electronic devices. In the context of a smart pet feeder, load sensors are typically used to measure the weight of the pet food remaining in the feeder's container. By continuously monitoring the weight, the feeder can determine when to dispense more food and when to alert the owner that the container needs refilling. The load sensor is typically placed underneath the food container or integrated into the feeder's dispensing mechanism. When food is added or removed from the container, the change in weight is detected by the load sensor. This information is then used to update the feeder's internal state and trigger actions such as dispensing food or sending notifications to the owner. Load sensors come in various shapes, sizes, and weight capacities to suit different applications. They can measure weights ranging from a few grams to several tons, making them suitable for a wide range of pet feeder sizes and types. In summary, load sensors play a crucial role in smart pet feeders by accurately measuring the amount of food remaining in the feeder's container. This allows for precise feeding schedules, prevents overfeeding or underfeeding, and provides owners with real-time information about their pet's feeding habits.

Ultra Sonic Sensor: An ultrasonic sensor operates on the principle of emitting high-frequency sound waves and measuring the time it takes for the waves to bounce back. This allows the sensor to calculate the distance between bowl and pet in its path. It takes distance between the bowl and pet as input and send it to the micro controller, which is ESP32, and it calculate weather to open the bowl or not. An ultrasonic sensor is a device that measures the distance to an object by emitting ultrasonic sound waves and then detecting the time it takes for the waves to bounce back. These sensors are commonly used in various applications, including robotics, industrial automation, and, relevantly, in smart pet feeders. The operation of an ultrasonic sensor is based on the principle of echolocation, like how bats and dolphins navigate. The sensor emits a burst of ultrasonic sound waves, which travel through the air until they encounter an object. When the waves hit the object, they are reflected to the sensor. By measuring the time it takes for the waves to travel to the object and back, the sensor can calculate the distance to the object. In the context of a smart pet feeder, an ultrasonic sensor can be used to detect the presence of the pet near the feeder or to prevent the feeder from dispensing food if the pet is too close. This helps prevent accidents and ensures the safety of the pet. The ultrasonic sensor is typically mounted on the exterior of the pet feeder, facing outward. When the sensor detects an object within its range, it sends a signal to the feeder's control system, which can then take appropriate action, such as pausing the feeding process or emitting a warning signal. One advantage of ultrasonic sensors is their ability to work in various environmental conditions, including darkness and dust, unlike optical sensors which may be affected by ambient light. Additionally, ultrasonic sensors have a longer range compared to infrared sensors, making them suitable for detecting larger objects or pets from a distance. However, ultrasonic sensors may have limitations in highly reflective or acoustically noisy environments, which could affect their accuracy. Additionally, they may not be suitable for detecting certain types of objects, such as soft or absorbent materials, which may absorb the sound waves rather than reflecting them back to the sensor. In summary, ultrasonic sensors offer a reliable and versatile solution for detecting objects and ensuring the safety and functionality of smart pet feeders. By accurately measuring distances and detecting the presence of pets, they contribute to a more efficient and user-friendly feeding experience for both pets and their owners.

Servo Motor: Our Smart Pet Feeder System's servo motor integration transforms feeding by giving you exact control over the feeding bowl's cap's opening and closing. The servo motor provides the necessary force and precision to smoothly rotate the cap of the feeding bowl. Servo motor is different other motor since we have control over it, we can move cap of the bowl at any angle. A servo motor is a rotary actuator that allows for precise control of angular position. It consists of a motor coupled with a sensor for position feedback, typically a potentiometer or an encoder. Servo motors are widely used in various applications, including robotics, automation, and, relevantly, in smart pet feeders. In a smart pet feeder, a servo motor is often used to control the mechanism that dispenses

food into the pet's bowl. The servo motor can precisely rotate to a specific angle, allowing for accurate control over the amount of food dispensed. This enables the feeder to deliver precise portion sizes according to the pet's feeding schedule. Servo motors operate based on a closed-loop control system, where the position feedback from the sensor is compared to the desired position set by the user. The motor adjusts its rotation until the actual position matches the desired position, ensuring accurate and reliable operation. One of the key advantages of servo motors is their ability to provide precise control over position, speed, and torque. This makes them ideal for applications where accuracy and repeatability are critical, such as in smart pet feeders where consistent portion sizes are essential for the pet's health. Another advantage of servo motors is their compact size and high torque-to-weight ratio, allowing for efficient use of space in small devices like pet feeders. Additionally, servo motors are available in various sizes and torque ratings, making it easy to select the right motor for the specific requirements of the feeder.

Liquid Crystal Display (LCD): The integration of LCD makes a crucial feature of system, which very help full for interaction between the pet's owner and system. The LCD display provides a visual representation of the pet's distance from the feeder, making it possible to monitor this crucial interaction. The LCD display provides this crucial information by displaying the weight of the food within the feeder in real time. Using I2C with LCD modules simplifies the hardware design, reduces pin count, and offers flexibility and ease of use. The LCD serves as a crucial component in the user interface of the proposed smart pet feeder system. It provides real-time visual feedback to the user, displaying important information such as feeding schedules, remaining food levels, system status, and alerts or notifications. Integrated with the microcontroller, typically an ESP32, the LCD communicates with the firmware to dynamically update its content according to user interactions and system events. This interaction layer allows pet owners to easily monitor and manage their pet's feeding regimen, ensuring timely and accurate dispensing of food. By presenting information in a clear and intuitive manner, the LCD enhances the user experience, providing convenience and peace of mind to pet owners even when they are not physically present.

Speaker: The Buzzer in smart pet feeder will communicate with the pet, it is for owner to call pet for feeding. The speaker in our Smart Pet Feeder is more than a device, it is a conduit for connection and communication with the pet, ensuring they receive the nourishment they need in a manner that resonates with their natural instincts.

Internet of Things (IoT): This is a network of interconnected devices that communicate and exchange data with each other over the internet, without requiring human intervention. These devices can range from everyday objects like home appliances and wearable devices to industrial machines and smart infrastructure. In the context of smart pet feeders, IoT technology enables the feeder to connect to the internet, allowing for remote monitoring, control, and automation. One of the primary benefits of IoT in smart pet feeders is remote access. Pet owners can use their smartphones or computers to

check on their pets and control the feeder from anywhere with an internet connection. This enables them to adjust feeding schedules, dispense food, and receive notifications about their pet's feeding habits, even when they're away from home. Additionally, IoT enables data collection and analysis, providing valuable insights into the pet's behavior and health. Smart pet feeders equipped with sensors can track factors such as feeding frequency, portion sizes, and food consumption patterns. This data can be used to monitor the pet's health and detect any changes in eating habits that may indicate underlying issues.

Inter-Integrated Circuit (I2C): The Inter-Integrated Circuit (I2C) protocol plays a crucial role in the communication infrastructure of the proposed smart pet feeder system. By facilitating communication between the microcontroller, sensors, and actuators, I2C enables seamless data exchange within the system. The microcontroller acts as the master device, orchestrating the communication process and controlling various peripherals such as sensors for monitoring food levels and environmental conditions, as well as actuators for dispensing food or indicating system status. Through the use of only two wires, I2C streamlines the connection of multiple devices, allowing for efficient and reliable communication in a compact space, such as inside the pet feeder. This simplicity and versatility make I2C an ideal choice for integrating diverse components within the smart pet feeder system, ensuring its functionality and responsiveness to user needs.

IV. ARCHITECTURE OF PROPOSED SYSTEM

The architecture of the proposed smart pet feeder system encompasses various components that work together to provide automated feeding, monitoring, and control functionalities. The system architecture can be broken down into several layers. The journey to create a fully automated smart pet feeder begins with the careful assembly of essential hardware components. This includes the ESP32 microcontroller, which acts as the brain of the system, along with a load sensor, ultrasonic sensor, servo motor, and LCD display.

The ESP32 microcontroller is the heart of the system, managing data collection, processing, and control logic. It ensures smooth communication between all the components. The load sensor, paired with the HX711 amplifier, is responsible for precisely measuring the weight of the food bowl. The ultrasonic sensor detects the presence of the pet and triggers the opening of the food bowl when pet approaches. The servo motor controls the opening and closing of the bowl cap, helping to keep the food fresh.

The system also features an LCD display that provides real-time feedback, giving pet owners a glimpse into their pets' feeding habits. A unique feature of this system is the pre-recorded voice message that calls the pet to the feeding area during mealtimes. If needed, the system can also send reminders to the pet to eat their meal slowly, ensuring a relaxed dining experience.

The smart pet feeder system is designed with a focus on pet health, efficiency, and sustainability. It uses food preservation strategies to provide timely meals, minimize food waste, and maintain food quality. The system undergoes rigorous testing to ensure its functionality, reliability, and accuracy, providing peace of mind for pet owners.

By leveraging technology and innovation, the fully automated smart pet feeder enhances the lives of pets and their owners while promoting sustainable pet care practices. This is not just a research methodology, but a step towards a future where technology makes pet care easier and more efficient.

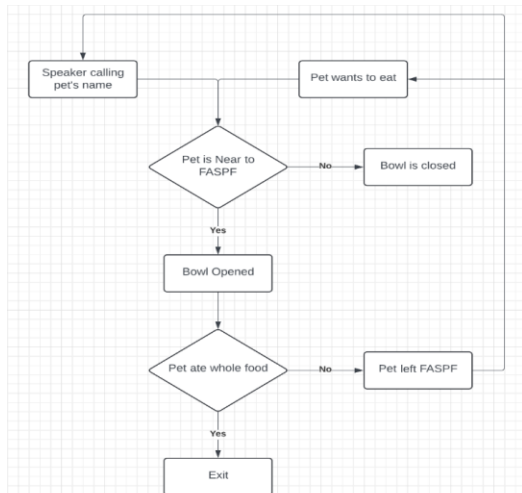

Fig.1.1 Flowchart to explain the working of the model

The fig 1.1 describes the Flow Chart of the proposed research paper; The working starts from the "pet wants to eat" or as per regular eating time of pet "Speaker will call pet". Now we have a case that if the pet near to the pet feeder, then the bowl will open else it will remain close. Now after this we one more very important case whether pets eat whole food then flow chart or system exit but if pet leave the pet feeder without eating the food

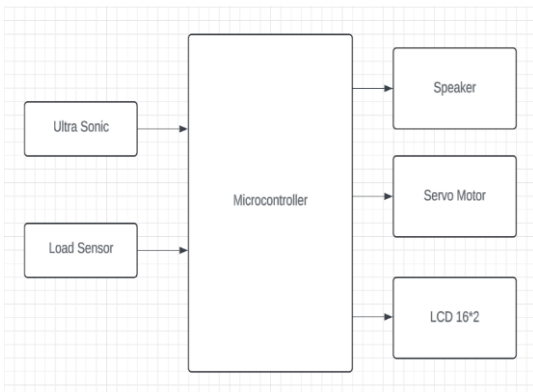

Fig.1.2 Flowchart to explain the input and output sensors of the model

The fig 1.2 shows the Block Diagram of the proposed research paper; The Ultra Sonic sensor and Load Sensor are working as

input sensors which will give input data about weight of food in the bowl and distance between pet and pet feeder to the microcontroller respectively. Now Speaker, Servo motor, and LCD 16*2 are output sensors, Speaker will call the pet, Servo Motor rotates the bowl's lid and LCD will display the weight of food in bowl and distance between pet and pet feeder.

The research in this area highlights the potential of smart pet feeders to improve the well-being of pets and provide convenience to pet owners through automation and remote monitoring. By addressing various aspects such as hardware design, sensor technology, connectivity features, and user interface, researchers are paving the way for more intelligent and responsive pet care solutions that cater to the evolving needs of both pets and their owners. In many Smart Pet Feeder projects proposed by various authors, measures to prevent food wastage are noticeably absent. When a pet does not eat its food or drink water, the food remains exposed in an open bowl, which can lead to potential spoilage and waste due to factors such as dust.

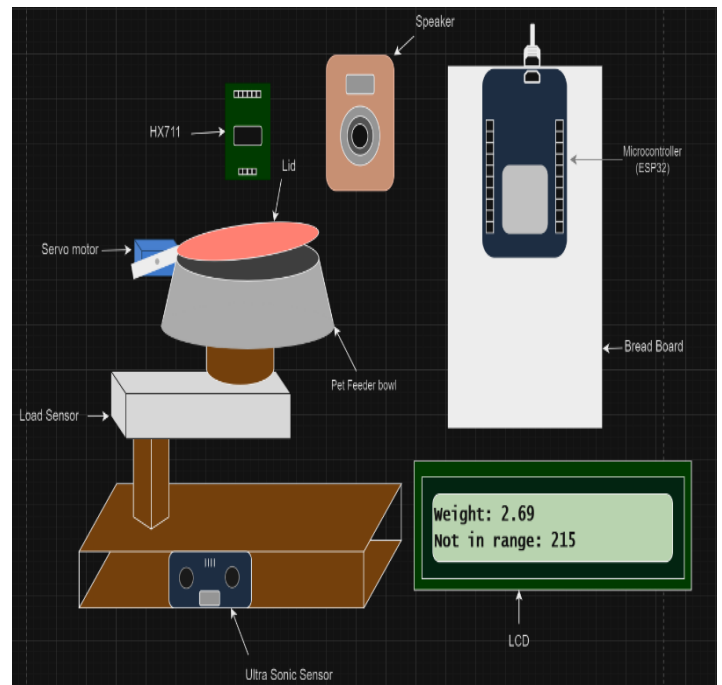

Fig. 2. Blueprint of the prototype

The fig 2 is the prototype of the proposed research paper. It is the Visual representation of all the sensors and how they are arranged together. The main setup for bowl was placed above the load sensor which is fix with a wooden block for calculating its weight while the servo motor placed along the bowl to open and close the lid. Ultra Sonic sensor placed in front of wooden block to catch pets' movement and LCD 16*2 is placed front of microcontroller to display weight and distance and Speaker is behind the bowl to look like the pet feeder is calling to eat food.

V. CONCLUSION

In conclusion, as the pet owners around the world are facing a common challenge: ensuring the well-being and health of their beloved companions, this innovation of this Fully Automated Smart Pet Feeder system will imprint a significant advancement in pet care management as well as keeping their healthy diet going on. The integration of an inbuilt smart system that does not need any internet connectivity and passing over the involvement of cloud technology, we can reduce the cost by considering microcontroller without Wi-Fi technology, saving money. This system incorporates variety of features, including a lid mechanism connected with a servo motor to open and close the lid of the bowl or pet food container, a speaker system which will create sound for the pet to alerting and motivating them to finish their left-over food, and sensor-based mechanism which helps the system by weighing the quantity of food and starting an alert trigger to motivate their pet to eat. Through this Fully Automated Smart Pet Feeder system for pet owners will ensure that pet don't have to wait for their owner to feed them, ensuring that the pet's get-well feed in their absence. As well as the system incorporated will become a cheaper option among the other smart pet feeder present. Hence, giving a cheaper alternative to the pet owners.

REFERENCES

- [1] Suffian, M. S. Z. M., Zaini, A. N. H. A., Jamali, A., Mohamaddan, S., & Ashari, M. F. (2021, March). Reliable smart pet feeding machine using Arduino Uno starter kit. In *IOP Conference Series: Materials Science and Engineering* (Vol. 1101, No. 1, p. 012033). IOP Publishing.
- [2] Marlina, E. (2023). The Design of Smart Prototype Pet Feeder Using Passive InfaRed (PIR) Sensors. *Journal of Computer Networks, Architecture and High-Performance Computing*, 5(1), 313-320.
- [3] Jukan, A., Masip-Bruin, X., & Amla, N. (2017). Smart computing and sensing technologies for animal welfare: A systematic review. *ACM Computing Surveys (CSUR)*, 50(1), 1-27.
- [4] Boateng, M. A., & Akparibo, A. R. (2022, December). A Multifunctional Automatic Dog-Feeder with Bluetooth and Wi-Fi Connectivity. In *2022 IEEE 2nd International Conference on Mobile Networks and Wireless Communications (ICMNWC)* (pp. 1-6). IEEE.
- [5] Bembde, M., Ranjan, N. M., Kamble, P., Chavan, A., Yelmar, A., & Mane, R. (2023, June). Robotic Day-Care for Pets using Sensors and Raspberry Pi. In *2023 International Conference on Sustainable Computing and Smart Systems (ICSCSS)* (pp. 994-999). IEEE.
- [6] Halachmi, I., Guarino, M., Bewley, J., & Pastell, M. (2019). Smart animal agriculture: application of real-time sensors to improve animal well-being and production. *Annual review of animal biosciences*, 7, 403-425.
- [7] Jain, E., Badwaik, S., Khirwadkar, S., Thakare, S., Uike, M., & Chandankhede, P. H. (2023, March). Design of smart pet food dispenser using embedded system. In *2023 International Conference on Emerging Smart Computing and Informatics (ESCI)* (pp. 1-5). IEEE.
- [8] Hidayat, M. A., & Jayakrista, S. Smart Pet Feeder on Cat Food Portions Using Mamdani's Fuzzy Logic Inference System Method. *Journal of Computer Engineering, Electronics and Information Technology*, 2(1), 13-28.
- [9] Tauseef, M., Rathod, E., Nandish, S. M., & Kushal, M. G. (2024, March). Advancements in Pet Care Technology: A Comprehensive Survey. In *2024 4th International Conference on Data Engineering and Communication Systems (ICDECS)* (pp. 1-6). IEEE.
- [10] Jukan, A., Masip-Bruin, X., & Amla, N. (2017). Smart computing and sensing technologies for animal welfare: A systematic review. *ACM Computing Surveys (CSUR)*, 50(1), 1-27.
- [11] P. N. Vrishanka, P. Prabhakar, D. Shet and K. Rupali, Automated Pet Feeder using IoT, In *2021 IEEE International Conference on Mobile Networks and Wireless Communications (ICMNWC)*, Tumkur, Karnataka, India, 2021, pp. 1-5, doi: 10.1109/ICMNWC52512.2021.9688391.
- [12] M.K Razali Et.al (April 2021), Smart Pet Feeder System and Big Data Processing to Predict Pet Food Shortage, In *2021 Turkish Journal of Computer and Mathematics Education (TURCOMAT)* 12(3):1858-1865, doi: 10.17762/turcomat.v12i3.1015
- [13] Brianbojoyou J (November 2023), Automated Pet Feeder with RFID Technology using Design Thinking Approach, In *2023 International Journal for Research in Applied Science and Engineering Technology* 11(11):1090-1096, doi:10.22214/ijraset.2023.56668
- [14] Maya Shelke, Nihar Madhaw Ranjan, Prathamesh kakasaheb Kamble, AditiChavan,ditya Yelmar, Rohan Mane (July 2023), Robotic Day-Care for Pets using Sensors and Raspberry Pi, In *2023 International Conference on Sustainable Computing and Smart Systems (ICSCSS)*, doi:10.1109/ICSCSS57650.2023.10169742
- [15] N. H. Kha, N. D. P. Trong, M. N. Triet, T. D. Khoa (January 2024), Blockchain-Driven Pet Healthcare: Integrating NFTs, IPFS, and Smart Contracts for Enhanced Pet Medical Data Management, In *2024 International Conference on Services Computing*, doi:10.1007/978-3-031-51674-0_3
- [16] Andi Adriansyah, Muchd Arief Wibowo, Eko Ihsanto, (October 2016), Design of Pet Feeder using Web Server as Internet of Things Application, In *2016 2nd International Conference on Electrical Engineering and Informatics (Icon-EEI 2016)*At: Pekanbaru, Riau, Indonesia